

Suggested Label Dimensions

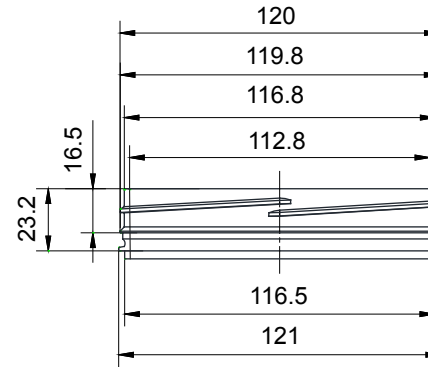

Sleeve Dimensions



Screw Neck

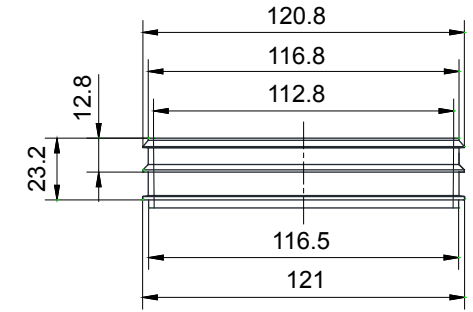

Snap On Neck

**Neck Details**

See Neck Details Drawing

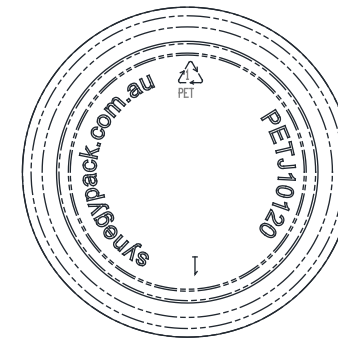
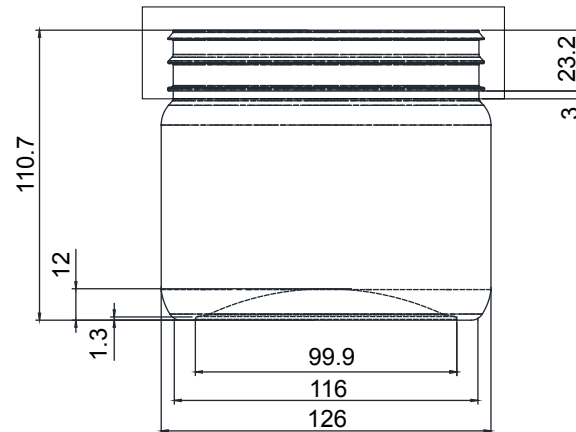

**Bottom View**

Brimful: 1100±100ml

Height/Lengh	Tolerance
<1	±0.2
>1	±0.4
>5	±0.8
>50	±1.0
>100	±1.6
>200	±2.0
Diameter	Tolerance
<25	±0.4
>25	±0.8
>50	±1.2



Material	PET	Drawing no.	W10120-J120-17-01	Controlled Document
Weight	Min. 100g	Description 1L Wide Mouth Jar with 120mm Screw or Snap On Neck W10120RW / W10120JC		
Scale	1:3			
Unit	mm			
Drawn by	A.Song			
Approved by		<p style="text-align: center;"><b>Synergy Packaging</b></p> <p style="text-align: right;">* Customer Copy *</p>		
Revision	Date			

1	26/06/17	Updated suggested label dimensions
0	14/12/16	
Revision	Date	Modifications