

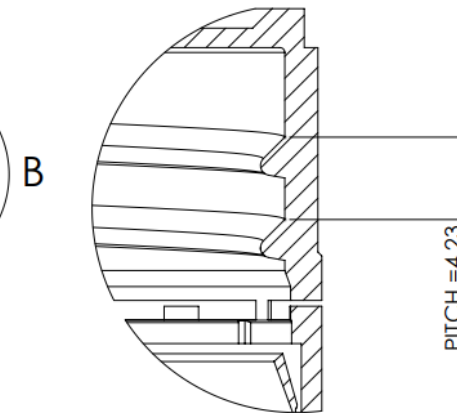

SECTION A-A



DETAIL B

Revision	Date	Modifications	Material	PP & PE	 		
00	03/11/16	New specification	Weight	4.75±0.35g			
01	06/12/23	New tooling - technical drawing updated to reflect supply	Scale	NTS	Unit	mm	<b>Description:</b> Ribbed Wall Wadded & Inducted Screw cap to suit tampertel Neck 38TT
			Drawn by	Supplier			
			Approved by:	<i>M. Bonnici</i>			